

# HOA1180

## Reflective Sensor

### FEATURES

- Choice of phototransistor or photodarlington output
- High sensitivity
- Wide operating temperature range (- 55°C to +100°C)
- 12.0 in.(305 mm) min. 28 AWG PVC insulated wire leads



INFRA-24.TIF

### DESCRIPTION

The HOA1180 series consists of an infrared emitting diode and an NPN silicon phototransistor (HOA1180-001, - 002) or photodarlington (HOA1180-003), encased side-by-side on converging optical axes in a black thermoplastic housing. The detector responds to radiation from the IRED only when a reflective object passes within its field of view. The HOA1180 series employs metal can packaged components. For additional component information see SE1450, SD1440, and SD1410.

Housing material is polyester. Housings are soluble in chlorinated hydrocarbons and ketones. Recommended cleaning agents are methanol and isopropanol.

Wire color code and functions are:

All devices  
 IRED anode - Red  
 IRED cathode - Black

HOA1180-001  
 Collector - Brown  
 Emitter - Black

HOA1180-002  
 Collector - Orange  
 Emitter - Black

HOA1180-003  
 Collector - Yellow  
 Emitter - Black

### OUTLINE DIMENSIONS in inches (mm)

Tolerance 3 plc decimals ±0.010(0.25)  
 2 plc decimals ±0.020(0.51)

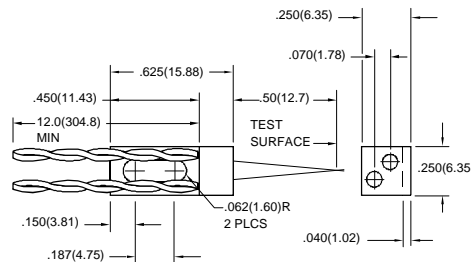

DIM\_035.d54

# HOA1180

## Reflective Sensor

### ELECTRICAL CHARACTERISTICS (25°C unless otherwise noted)

PARAMETER	SYMBOL	MIN	TYP	MAX	UNITS	TEST CONDITIONS
<b>IR EMITTER</b>						
Forward Voltage	$V_F$			1.6	V	$I_F=20\text{ mA}$
Reverse Leakage Current	$I_R$			10	$\mu\text{A}$	$V_R=3\text{ V}$
<b>DETECTOR</b>						
Collector-Emitter Breakdown Voltage HOA1180-001, -002 HOA1180-003	$V_{(BR)CEO}$	30 15			V	$I_C=100\text{ }\mu\text{A}$
Emitter-Collector Breakdown Voltage	$V_{(BR)ECO}$	5.0			V	$I_E=100\text{ }\mu\text{A}$
Collector Dark Current HOA1180-001, -002 HOA1180-003	$I_{CEO}$			100 250	nA	$V_{CE}=10\text{ V}$ $I_F=0$
<b>COUPLED CHARACTERISTICS</b>						
On-State Collector Current HOA1180-001 HOA1180-002 HOA1180-003	$I_{C(ON)}$	0.04 0.16 2.0			mA	$V_{CE}=5\text{ V}$ $I_F=30\text{ mA}$ (1)
Collector-Emitter Saturation Voltage HOA1180-001 HOA1180-002 HOA1180-003	$V_{CE(SAT)}$			0.4 0.4 1.1	V	$I_F=30\text{ mA}$ (1) $I_C=5\text{ }\mu\text{A}$ $I_C=20\text{ }\mu\text{A}$ $I_C=250\text{ }\mu\text{A}$
Rise And Fall Time HOA1180-001, -002 HOA1180-003	$t_r, t_f$		15 75		$\mu\text{s}$	$V_{CC}=5\text{ V}, I_C=1\text{ mA}$ $R_L=1000\text{ }\Omega$ $R_L=100\text{ }\Omega$

#### Notes

1. Test surface is a front surface mirror (polished aluminum, 85% reflectance) located 0.50 in. (12.7 mm) from the front surface of the device.

### ABSOLUTE MAXIMUM RATINGS

(25°C Free-Air Temperature unless otherwise noted)

Operating Temperature Range -55°C to 100°C

Storage Temperature Range -55°C to 125°C

Soldering Temperature (5 sec) 240°C

#### IR EMITTER

Power Dissipation 75 mW (1)

Reverse Voltage 3 V

Continuous Forward Current 50 mA

#### DETECTOR

Collector-Emitter Voltage 30 V

Emitter-Collector Voltage 5 V

Power Dissipation 75 mW (1) 75 mW (1)

Collector DC Current 30 mA 30 mA

#### TRANS. DARLINGTON

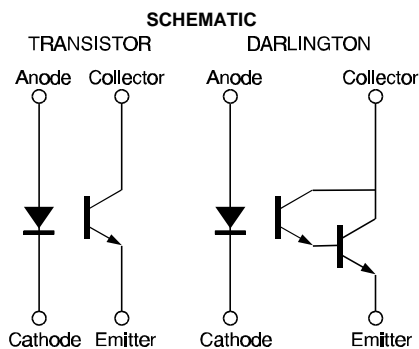

Honeywell reserves the right to make changes in order to improve design and supply the best products possible.

# Honeywell

# HOA1180

## Reflective Sensor

Fig. 1 IRED Forward Bias Characteristics

gra\_073.ds4

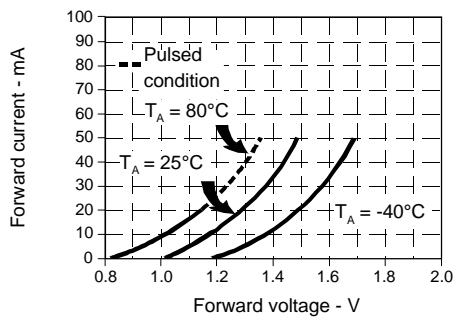

Fig. 2 Non-Saturated Switching Time vs Load Resistance

gra\_079.ds4

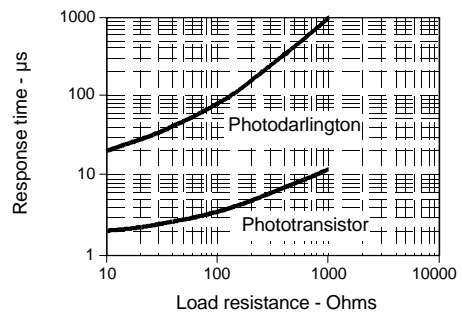

Fig. 3 Dark Current vs Temperature

gra\_303.cdr

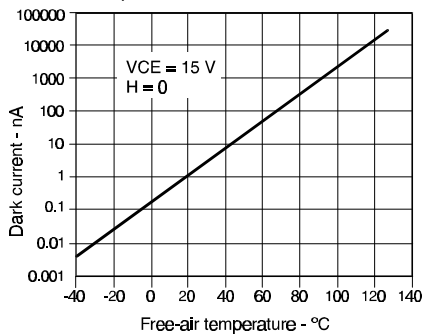

Fig. 4 Collector Current vs Ambient Temperature

gra\_076.ds4

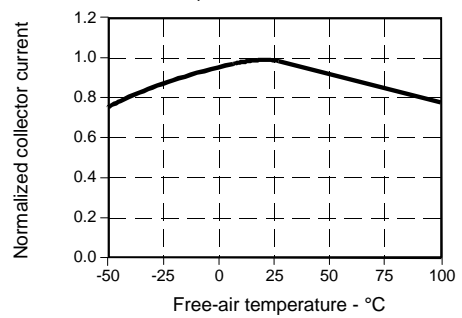

Fig. 5 Collector Current vs Distance to Reflective Surface

gra\_084.ds4

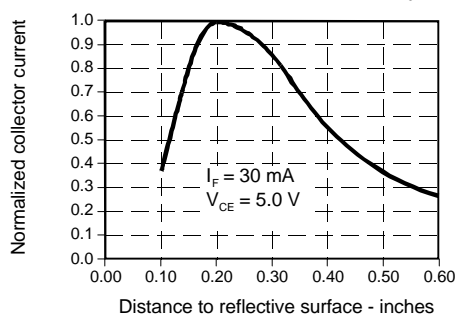
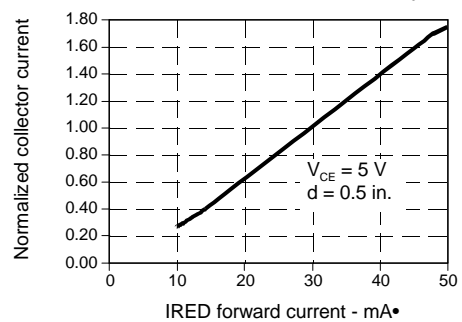

Fig. 6 Collector Current vs IRED Forward Current

gra\_085.ds4



All Performance Curves Show Typical Values

**HOA1180**  
Reflective Sensor

---



Honeywell reserves the right to make changes in order to improve design and supply the best products possible.

**Honeywell**